

# E. 112<sup>th</sup> Ave. Ditch Improvement Project Interim Flood Control Measures

March 5, 2024



# Community Engagement

- Nov. 16, 2023 -- Community Meeting with Residents
- Alternatives identified by residents assessed for interim flood control measures
  - Increasing inlet capacity
  - Noise wall
  - Containing runoff on street
  - Increasing ditch capacity

# Approach to Determining Interim Flood Protection Measures

- Understand the problem – root cause is capacity limitations of ditch that result in overflows onto E 112<sup>th</sup> Ave
- Identified wide range of alternatives
  1. Flood Barriers
  2. Conveyance Improvements
  3. Combinations of Barriers and Conveyance
- Evaluated pros and cons of alternatives
- Conducted site walk with MHFD and City
- Developed recommended actions



# Two Options for Interim Measures

- Keep water in street

PROs:

- Increase conveyance in street
- Increase threshold for overtopping
- Mitigate impact to homeowners

CONS:

- Traffic impacts during storms
- Increased depth and spread in street (within criteria for collector)

- Allow street overtopping – collect and convey in southside easements

PROs:

- Reduce traffic impacts during storms
- Platted easements exist

CONS:

- Constructability issues with limited space and slope of ROW south of E. 112<sup>th</sup> Ave.
- Drainage easements not functional
- Disruption to residents

# Current Piping System/Drainage Paths



- Inlet
- Storm Drain
- 30" Pipe Diameter
- ▭ Properties Impacted by Summer 2023 Rain Events

24"

E 112<sup>th</sup> Ave

48"

Irma Drive

48"

E 110<sup>th</sup> Pl

30"

30"

Leroy Drive

48"

60"

72"

Culvert

Muriel Drive

48"

# PROPOSED INTERIM PLAN SHEET 1/2

**Legend**

- Parcels
- Drainage Easement
- Storm Drain
- Inlet
- Temporary Measure

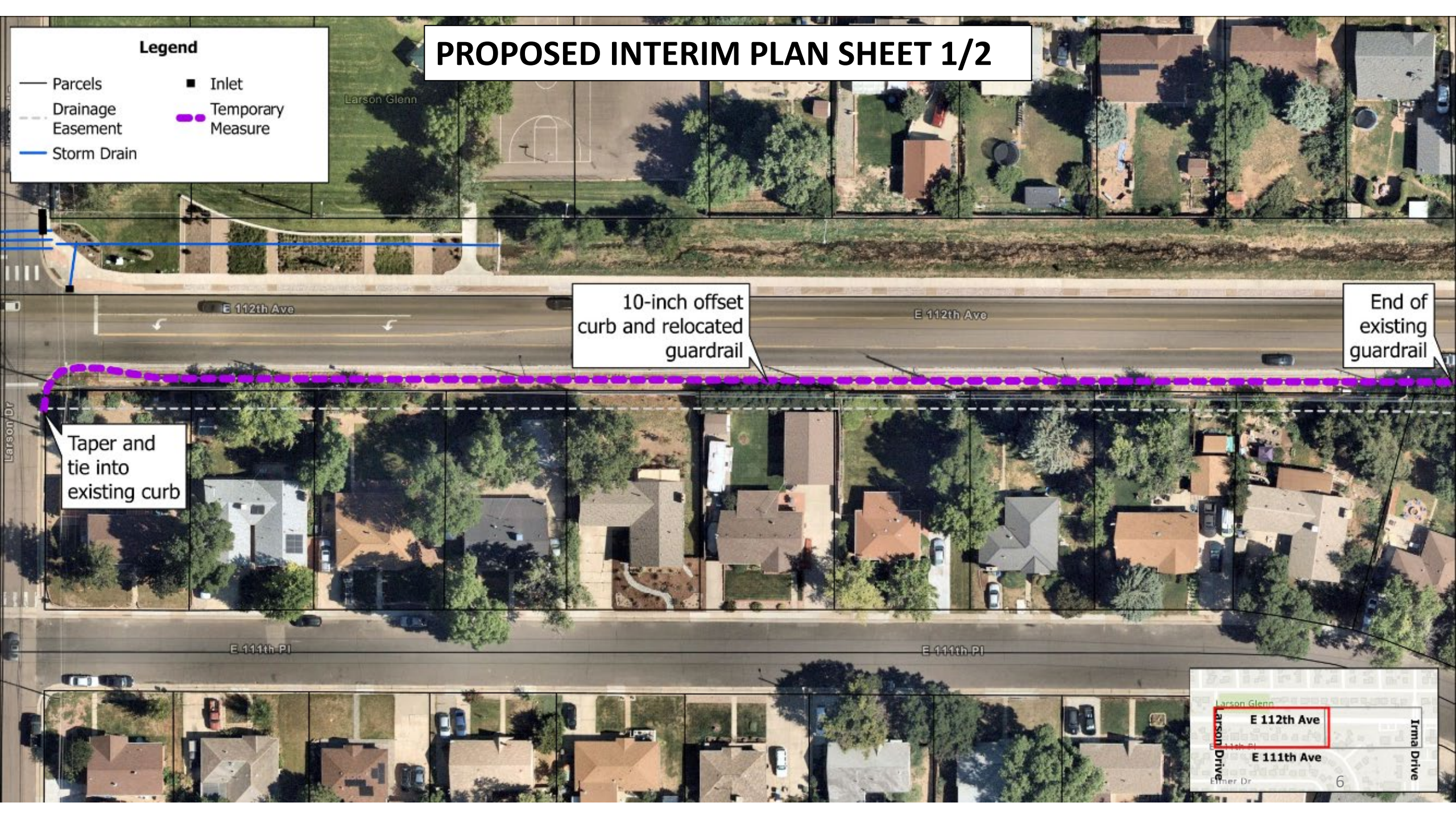

10-inch offset curb and relocated guardrail

End of existing guardrail

Taper and tie into existing curb

Larson Glenn  
E 112th Ave  
E 111th Ave  
Larson Drive  
Irma Drive  
Ethmer Dr

6



*Existing curb and guardrail*



Offset curb  
will be  
raised

*Proposed curb and guardrail*

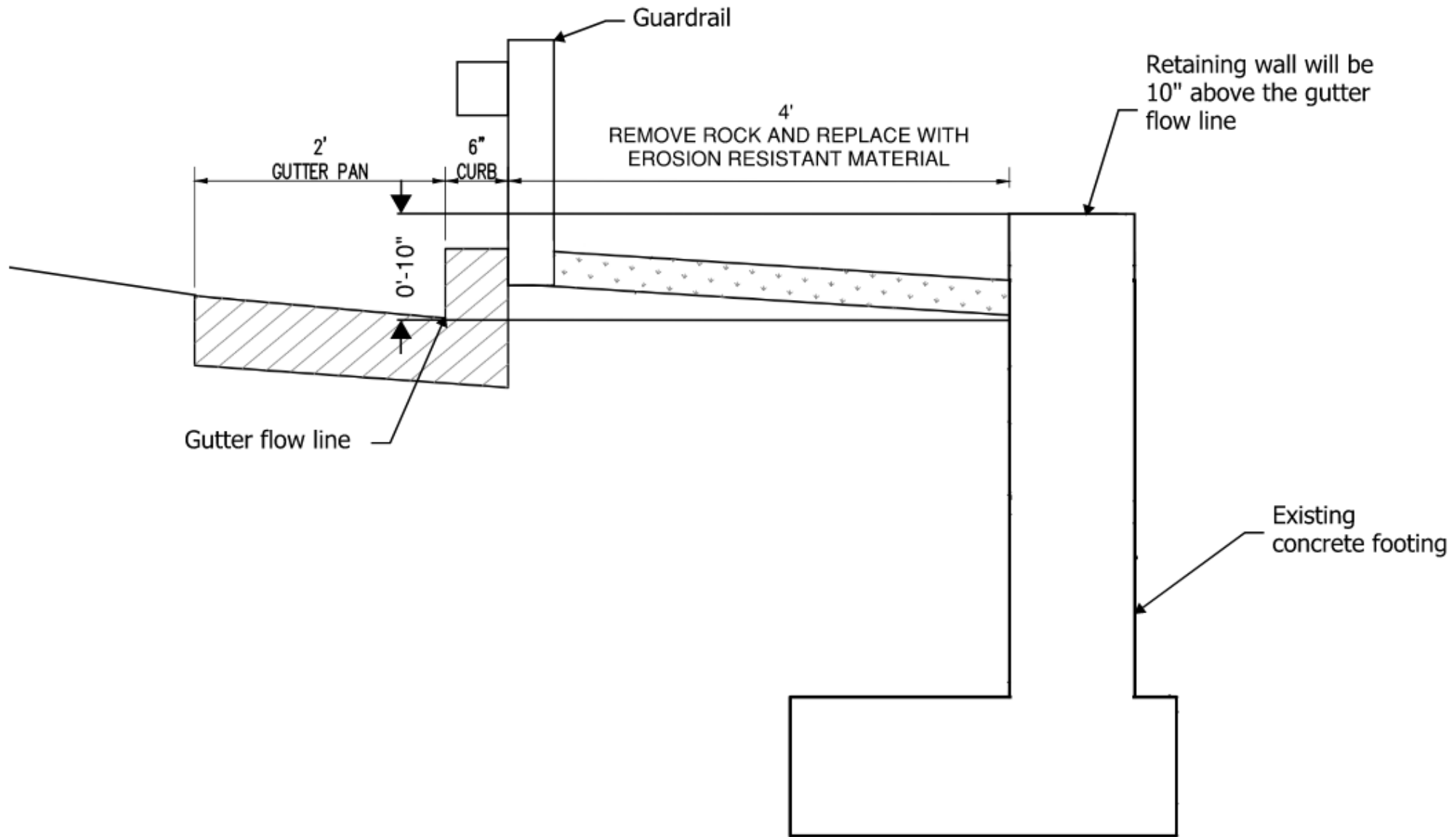

**"Slice" inside view of curb and guardrail on south side of E 112th  
 You are facing Irma Drive, with Larson Drive behind you**



# PROPOSED INTERIM PLAN SHEET 2/2

**Legend**

- Parcels
- Drainage Easement
- Storm Drain
- Inlet
- Temporary Measure

End of existing guardrail

Extend 10-inch offset curb to NURA property

End of new guardrail

Temporary flood barrier for NURA frontage



# Additional Information

**Costs:** Funded by MHFD

**Timeline:** Construction to begin in late April 2024, to be completed by early summer 2024

## **Next Steps:**

1. Finalize design details and pricing
2. Contractor will mobilize and place jersey barriers (temporary flood protection)
3. Construction will begin (by late April)
4. Offset curb and temporary barrier installed by summer 2024
5. Ongoing analysis and design of long-term solutions
6. Implementation of long-term solutions – timeline depending on funding, may be phased

# Ongoing Ditch Maintenance

- MHFD:
  - will conduct vegetation management and debris removal once/month between April & October
- City of Northglenn:
  - Hired a contractor to clear vegetation 2 times a year, spring and late summer
  - Parks Maintenance will mow as needed
  - Will continue to inspect and monitor



# Potential Long-Term Solutions Being Evaluated

- Upsizing the culverts at Larson and Irma
- Steepen channel between Larson and Irma
- Line channel bottom with concrete
- Upsizing the inlet and pipe on the south side of E 112<sup>th</sup> Ave
- Adding a storm drain along the north-south drainage easement between residential and commercial properties
- Putting ditch in box culvert in conjunction with potential future road expansion

**QUESTIONS OR COMMENTS?**